

General Specifications

GS 05G01B22-01E

Model LL200 PC-based Custom Computation Building Tool (with Parameters Setting Function and Multi-monitoring Function)



■ General

The LL200 PC-based Custom Computation Building Tool is a software package used to create custom computation and custom display functions for the UT/UP750 controllers. This tool also covers the parameter setting function and multi-monitoring function of the LL100 PC-based Parameters Setting Tool. The custom computation building function, the main function of this package, enables users to formulate computations graphically. This tool has an online help function that provides explanations of the computation modules.

■ Custom Computation Building Functions

Custom Computation Function:

Develops a custom computation for the controller by combining computation modules.

Computation Modules

Arithmetic computation

Addition, subtraction, multiplication, division, absolute value, reciprocal, auto-selector (min./max./average/difference), hold maximum value, hold minimum value, hold, switch, limiter, constant, and multi-selector.

Logic operation

AND, OR, exclusive OR, NOT, latch, greater, lesser, decremental counter, counter, equal-to, not-equal-to, range, delay, AND (long word), OR (long word), word shift, edge-triggered counter, and exclusive OR (word).

Special computation

Sum, timer, velocity limiter, 10-segment linearizer 1 and 2, inverse 10-segment linearizer 1 and 2, curve linearizer 1 and 2, ratio, first-order lag filter, EU-range conversion, switching between two inputs, temperature and humidity calculation, square-root extraction, detection of change, loop-1 output selection 1/11/12/13, loop-2 output selection 2/21, fluid temperature compensation, fluid pressure compensation, 10-segment linearizer 3 and 4, dead time, moving average, edge-triggered timer, detection of change at edge, square-root extraction 2, flow sum, flow sum 2, and BCD conversion.

Special function

Display data unit conversion, parameter setting, data display 1 and 2, output-1 terminal configuration, and output-2 terminal configuration.

Custom Display Function:

This function builds the controller's custom displays, according to the user-defined display function created, by configuring display elements and display sequences. Users can select operation displays from the display types provided, and set a display sequence and conditions for them.

Monitoring Function:

Users can monitor and confirm the behavior of the created custom computation by setting simulated input signals from a personal computer.

Communication Function:

When the controller operation is stopped, users can download the created custom computation data to the controller and upload the custom computation data from the controller. It is also possible to compare the custom computation data created using this tool with those in the controller.

File Management Function:

This function allows users to save the custom computation data created using this tool and those uploaded from the controller to the hard disk of a personal computer or a floppy disk. It is also possible to compare the custom computation data created using this tool with custom computation data files created in the past.

Printout Function:

Custom computation data can be printed out from a printer connected to a personal computer.

■ Parameters (Program) Setting Functions

Sets and changes the controller's parameters such as the controller mode (UT/UP mode), universal input/output selection, setup parameters, operating parameters, and program pattern parameters* (program/start conditions and patterns).

Note: Uploading/downloading/comparing parameters via Ethernet is impossible for the controller operated by custom computation function (UT mode 21 or UP mode 21). Use front communication or serial terminal communication.

*: For program controllers only.

Tuning Function:

This function is used to tune the PID parameters of the controllers. The PID parameters can be tuned and the auto-tuning function can be executed while the trend graphs of PV, SP, and control output are being displayed on a personal computer screen.

Downloading, Uploading, and Comparing Parameters:

When the controller operation is stopped, users can download the created parameter data to the controller and upload the parameter data from the controller. It is also possible to compare the parameter data created using this tool with data in the controller.

File Management Function:

This function allows users to save the parameter data created using this tool and those uploaded from the controller to the hard disk of a personal computer or a floppy disk. It is also possible to compare the parameter data created using this tool with parameter data files created in the past.

Printout Function:

Parameter data can be printed out from a printer connected to a personal computer.

Multi-monitoring Function

This function allows users to display and collect PV, SP, control output and alarm generating state as trend data. It is possible to detect two or more controllers (a maximum of 16 loops) connected to the personal computer automatically, and to display trend graphs on a personal computer screen.

Tuning Function:

This function is used to tune the PID parameters of the controller. The PID parameters can be tuned, the auto-tuning function can be executed for every connection loop and an operating mode can be changed while the trend graphs of PV, SP and control output are being displayed on a personal computer screen.

File Management Function:

The trend data collected by the monitoring function can be saved as a CSV format so that commercial spreadsheet software like Microsoft Excel can treat data. The saved trend data can be read and displayed as trend graph.

Parameter Setting Function for Ethernet Converter

Sets the parameters related to the Ethernet communication function of the Ethernet/RS485 converter, VJET.

Applicable Controllers

Custom computation, parameter setting functions and multi-monitoring function

- UT750 Digital Indicating Controller (with custom computation option)
- UP750 Program Controller (with custom computation option)

Parameter setting function and multi-monitoring function

- UT551 Digital Indicating Controller
- UT551-xA to xD Digital Indicating Controller
- UT550/520 Digital Indicating Controller
- UT450/420 Digital Indicating Controller
- UT351/321 Digital Indicating Controller
- UT351-xA Digital Indicating Controller
- UT350/320 Digital Indicating Controller
- UP550 Program Controller
- UP351 Program Controller
- UP350 Program Controller

Functions Restricted by Communication Method

Function \ Communication method	Front communication	Serial terminal communication	Ethernet communication
Custom computation	✓	✓	N/A
Parameter setting	✓	✓	Cond.
Program pattern setting	✓	✓	Cond.
Multi-monitoring function	✓	✓	✓

✓: Available.

Cond.: Not available when operated by custom computation function (ut mode 21 or UP mode 21).

N/A: Not available.

Connection between the Controller and a Personal Computer

[Via Dedicated Adapter]

By attaching a dedicated adapter to the controller's front panel, users can upload and download custom computation and parameter data to and from a personal computer (ML2).

To communicate via the dedicated adapter:

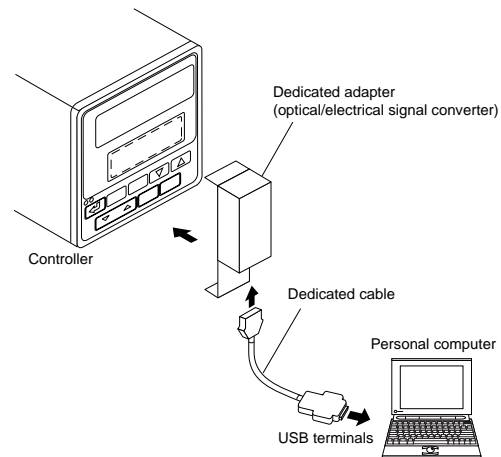

[Via RS-485 Communication Terminals]

Users can also upload and download custom computation and parameter data to and from a personal computer via the rear communication terminals of the controller. This connection requires an RS-232C/RS-485 converter (ML2).

To communicate via the communication terminals:

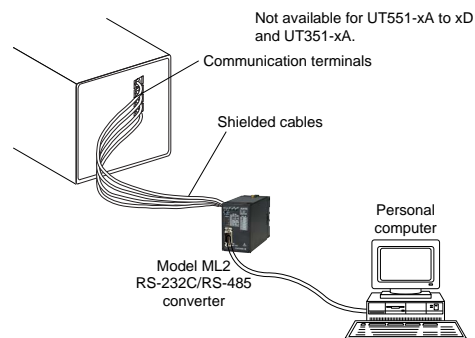

[Via Ethernet Communication Terminal]

The UT351-xA/UT551-xA to xD controllers can communicate with a personal computer via the Ethernet communication terminal. Connect a personal computer and a communication network using a cable that meets the 10BASE-T/100BASE-TX standards. Also, the UT351-xA/UT551-xA to xD controllers and VJET converter can use the Ethernet-serial gateway function to communicate with the GREEN Series controllers equipped with the communication functions via network. In this case, cross-connect the rear communication terminals in the back of the UT351-xA/UT551/VJET and of the GREEN Series controllers.

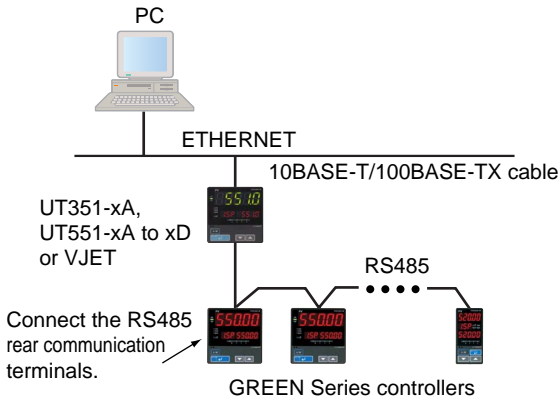

Operating Environment

Personal Computer:

- Windows 2000/XP-enabled IBM PC/AT compatible machine
Operating system: Windows 2000 (Professional)/XP (Home Edition/Professional)
CPU: 300-MHz Pentium processor or superior is recommended.
Main memory: 128 MB minimum is recommended.
Hard disk: Memory space required to store the tool's programs; 15 MB
Memory space required to store the parameter data; 2 MB minimum
Memory space required to store the driver for USB-Serial converter; 1 MB
CRT display: 800 x 600 pixels or superior
Smaller fonts should be used.
Should be capable of handling at least 256 colors.
USB communication port: One channel (COM1 to COM16), with SeriesA connector, compliant with USB Specification Rev1.1.
Network: 10BASE-T/100BASE-TX (required for Ethernet communication)
CD-ROM drive: Required for installation.
Printer: Required for printing. Windows 2000/XP-compatible A4-size printer

Dedicated Adapter

Communication method: Controller side; optical, contactless, bidirectional serial communication

Personal computer side; compliant with USB Specification Rev1.1

Power supply: Supplied from USB bus power (no internal battery)
Input rating: 4.4 to 5.25 V DC, 100 mA (including a dedicated cable)

* No plug for external power source, no power switch
Ambient temperature range: 0 to 50°C

Ambient humidity range: 20 to 90% RH (no condensation)

Transport and storage conditions: -20 to 65°C, 10 to 90%RH (no condensation)

Dust- and water-proof construction: Not applied.

Standard: CE Marking (EMC only)

Dedicated Cable

Built-in USB-Serial converter
Personal computer side: USB SeriesA plug
Adapter side: RJ45 (8-pin) plug
Cable length: Approx. 2.7 m

Packaged Contents

- CD (2 disks): LL200/USB converter driver software (1 disk)
User's Manual (Reference) (CD version) (1 disk)

Dedicated adapter and dedicated cable:

For connecting a personal computer and optical communication interface on the front of controller (1 set)

External Dimensions

Dedicated Adapter

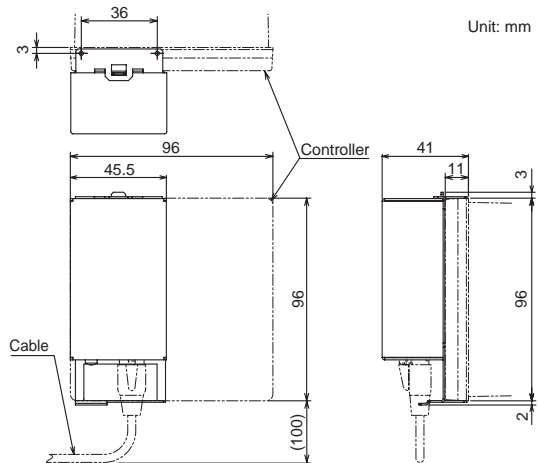

Dedicated Cable

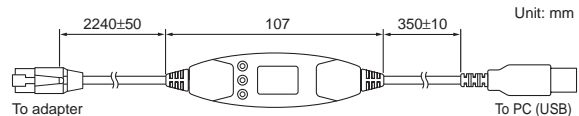

■ Model and Suffix Codes

Model	Suffix code	Description
LL200		PC-based Custom Computation Building Tool*
	-U10	Model for use with IBM PC/AT compatible machine (common to English and Japanese version), USB connection

* The LL200 PC-based Custom Computation Building Tool covers the parameter setting functions and multi-monitoring function of the LL100 PC-based Parameters Setting Tool.

Trademarks

- Windows 2000/XP are registered trademarks of Microsoft Corporation, USA.
- Pentium is a registered trademark of Intel Corporation, USA.
- Ethernet is a registered trademark of XEROX Corporation, USA.
- Other company and product names are trademarks or registered trademarks of their respective holders.